

# INSTALLATION INSTRUCTIONS

## Digimotor Test Tool

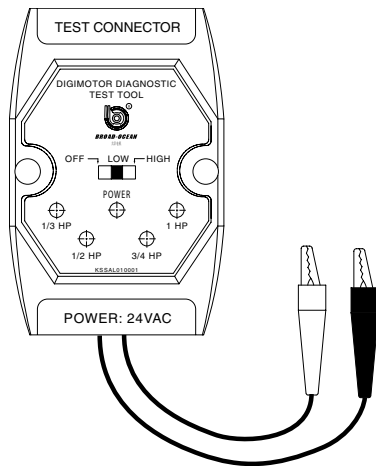

KIT CONTENTS	
QTY	DESCRIPTION
1	Digimotor Test Tool
1	Type A Test Connector (Furnaces, AH, & Packaged)
1	Type B Test Connector (Packaged Units)
1	Type C Test Connector (Air Handlers)
1	Type D Test Connector (Outdoor)

### **WARNING:**

#### **ELECTRICAL SHOCK, FIRE OR EXPLOSION HAZARD**

**Failure to follow safety warnings exactly could result in serious injury or property damage.**

**Improper servicing could result in dangerous operation, serious injury, death or property damage.**

- **Before servicing, disconnect all electrical power to furnace.**
- **When servicing controls, label all wires prior to disconnecting. Reconnect wires correctly.**
- **Verify proper operation after servicing.**

These instructions are primarily intended to assist qualified individuals experienced in the proper servicing of heating and air conditioning appliances. Some local codes require licensed installation/service personnel for this type equipment. Use of this tester must be in accordance with these instructions and with all applicable national and local codes and standards.

Read these instructions thoroughly before starting the test. Follow all precautions and warnings contained within these instructions and on the unit.

## TROUBLESHOOTING WITH THE BROAD OCEAN DIGIMOTOR TEST TOOL

ECM motors require 2 inputs to function properly; line voltage as specified on the unit rating plate and a control signal which is supplied by the unit control board or motor control board (if equipped). The Digimotor Test Tool replaces the control signal normally provided by the unit allowing the servicer to isolate an issue to either the motor or the control board and control wiring. The diagnostic tool does not provide line voltage to the motor. Before using the Digimotor Test Tool:

- Verify that the black and white power lines on the motor are receiving electrical service at the voltage, frequency and phase specified on the unit rating plate and are firmly connected as shown in the wiring diagram included with the unit.
- Verify that the green and yellow grounding wire is securely fastened to the unit chassis. Also verify that the electrical service provided to the unit meets the MCA and MOP requirements listed in the Installation Instructions supplied with the unit. Please consult local electrical code for details.

1. Before connecting the Digimotor Test Tool, shut off all power to the unit and make sure that the selector switch on the Digimotor Test Tool is in the OFF position.
2. The Digimotor Test Tool is equipped with 4 different test connections (see Figure 1). Select the connection that matches the motor to be tested and connect it to the TEST CONNECTOR port on the Digimotor Tool.
3. Disconnect the motor control connection from the control board and connect it to the test connector of the Digimotor Test Tool.

**NOTE:** For Type C connector, leave the power wires in place and remove the 24V control wires from the motor plug. Connect the tester to the motor plug by matching the wire colors. Connect the red wire with the male terminal to the female wire bundled with the motor wires. See Figure 1.

4. Connect the black and red alligator clips from the Digimotor Test Tool to **C** & **R** on the unit control board. See Figure 2. **NOTE:** For outdoor split systems, connect the alligator clips to both sides of the 24V coil on the unit transformer.
5. Restore power to the unit. The red LED (**POWER**) should illuminate indicating that the Digimotor Test Tool is receiving 24 Volts from the control board. **NOTE:** If the red light does not illuminate check the control connections between the control board and transformer. If the connections match the supplied wiring diagram there may be a defect in the control board, transformer or related wiring.
6. Move the selector switch from OFF to LOW. The motor should begin to turn after a short delay. A green LED should also illuminate which indicates the horsepower rating of the motor. Verify this to the horsepower information printed on the motor.

### Horsepower Reporting

- **Type A, B, & C Connectors:** The motor controller uses the horsepower rating provided by the motor to select the correct run settings in constant torque and constant CFM mode. If the horsepower indicated on the Digimotor Test Tool does not match the rating printed on the motor, the motor will not run at the correct speed and should be replaced.
- **Type D Connectors:** This application does not utilize horsepower reporting and will not illuminate any of the LED's

### Low Speed Operation

The behavior of the LOW speed setting varies with motor type:

- **Type A & D Connectors:** The Digimotor Test Tool will run the motor at approximately 500RPM on the LOW setting.
- **Type B & C Connectors:** The LOW setting will energize the lowest (M1) speed tap. See the Installation Instructions for details on speed settings.
- If the motor does not turn with the selector switch in the LOW position, there may be an issue with the motor or line voltage supply. Check the supply voltage. If receiving proper supply voltage, replace the motor.

7. Move the selector switch from LOW to HIGH.

### High Speed Operation

The behavior of the HIGH speed setting varies with motor type:

- **Type A & D Connectors:** The HIGH speed selection will operate the motor at twice the LOW speed setting. There should be an audible difference in blower speed.
- **Type B & C Connectors:** The HIGH speed selection energizes the highest (M5) speed tap. See the Installation Instructions for details on speed settings.
- If the motor runs at both selector switch settings and the reported horsepower matches the value printed on the motor, then the motor is functioning properly. Continue to troubleshoot the rest of the unit using the troubleshooting section in the Installation Instructions supplied with the unit.
- If the motor does not run at one or both speeds and supply voltage is correct, replace the motor.

8. Before removing the Digimotor Test Tool, shut off all power to the unit. Verify the red LED (POWER) is not illuminated and remove the red and black alligator clips from the control board.

9. Disconnect the Test Connection from motor and plug the motor connector back into the control board

10. Restore Power to the unit.

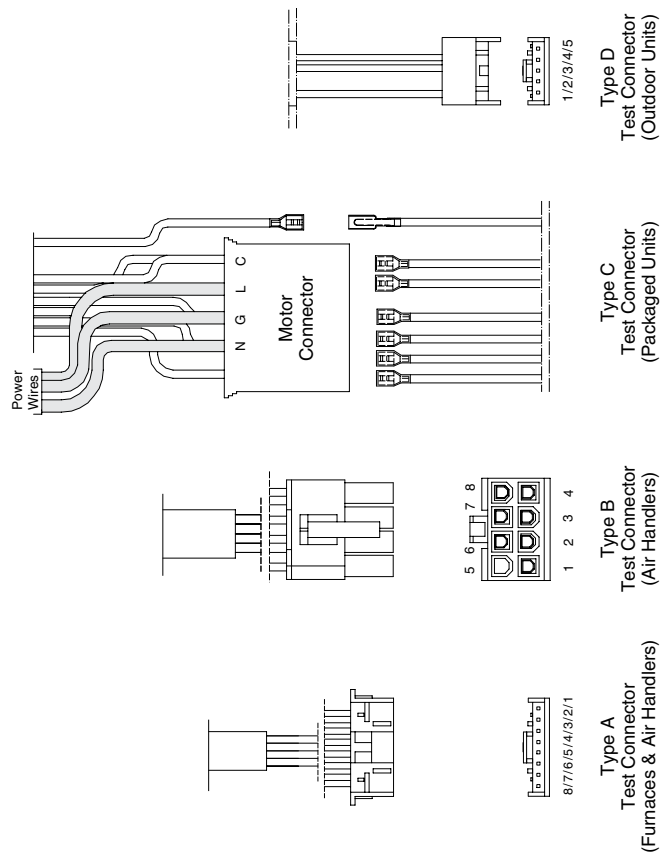

Figure 1. Digimotor Test Connectors

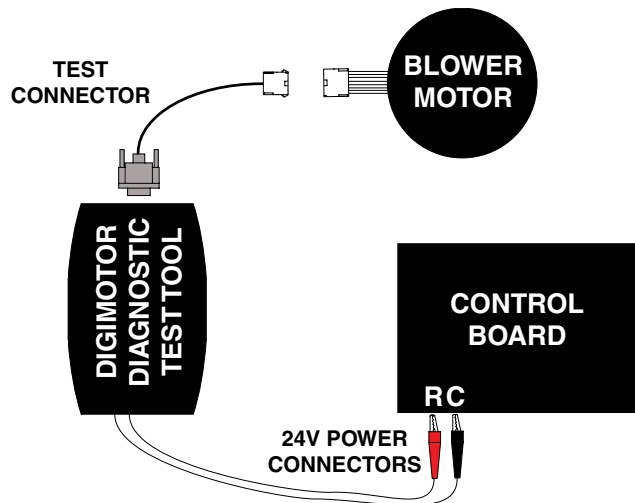

Figure 2. Digimotor Test Tool Setup