

Duct Application Smoke Detectors

Duct Application Smoke Detectors

Contents

Section 1	Introduction.	2
Section 2	Characteristics of Smoke in HVAC Systems	3
Section 3	Duct Smoke Detection Equipment	4
Section 4	Typical Air Handling Systems	5
Section 5	How Duct Detection Systems are Used to Control Smoke	6
Section 6	Procedure for Duct Smoke Detector Application and Installation	7
Section 7	Maintenance and Service of Detectors for Use in Ducts	10
Section 8	Glossary of Terms	12

Foreword

The purpose of this guide is to provide much needed information concerning the proper use of smoke detectors in duct applications. Duct mounted smoke detectors are designed to provide a specific type of protection that cannot be duplicated by any other type of system. However, there has been a tendency to misapply these devices in the past by attempting to use them as a substitute for an early warning smoke detection system. This fact, coupled with new methods of detecting smoke in ducts, has prompted the writing of this industry guide. Fire protection engineers, mechanical and electrical engineers, fire alarm system designers and installers should find the contents both educational and informative.

This information is intended as a technical guide, as distinct from mandatory requirements.

**Section 1
Introduction**

**Purpose of Duct
Smoke Detection**

National and local safety standards and codes recognize the ability of air duct systems to transfer smoke, toxic gases, and flame from area to area. Sometimes smoke can be of such quantity as to be a serious hazard to life safety unless blowers are shut down and dampers are actuated. **The primary purpose of duct smoke detection is to prevent injury, panic, and property damage by reducing the spread (recirculation) of smoke.** Duct smoke detection also can serve to protect the air conditioning system itself from fire and smoke damage, and can be used to assist in equipment protection applications, for example, in the ventilation/ exhaust duct work of mainframe computers and tape drives.

Perhaps more important is the identification of what duct smoke detection is not intended for rather than what it is.

- It is **not** a substitute for an area smoke detector.
- It is **not** a substitute for early warning detection.
- It is **not** a replacement for a building's regular fire detection system.

NFPA 90A supports this by stating: "Protection provided by the installation of smoke detectors and other related requirements is intended to prevent the distribution of smoke through the supply air duct system and, preferably, to exhaust a significant quantity of smoke to the outside. Neither function, however, will guarantee either early detection of fire or the detection of smoke concentrations prior to dangerous smoke conditions if smoke movement is other than through the supply air system."¹

NFPA 72, 2007, 5.7.4.2.2 states, "Detectors that are installed in the air duct system shall not be used as a substitute for open air protection."

Area smoke detectors are the preferred means of controlling smoke spread:

- Duct smoke detectors can only detect smoke when smoke laden air is circulating in the ductwork. Fans may not be running at all times, such as during cyclical operation or during temporary power failure.
- Duct smoke detectors sample great volumes of air from large areas of coverage. They cannot be expected to match the detection ability of area detectors.
- Dirt contaminated air filters can restrict air flow causing a reduction in the operating effectiveness of the duct smoke detectors.

Applications

NFPA 90A², "Standard for the Installation of Air Conditioning and Ventilating Systems", specifies that "Smoke detectors listed for use in air distribution systems shall be located as follows:

- (1) Downstream of the air filters and ahead of any branch connections in air supply systems having a capacity greater than 2,000 cfm (944L/sec).
- (2) At each story prior to the connection to a common return and prior to any recirculation or fresh air inlet connection in air return systems having a capacity greater than 15,000 cfm (7080 L/sec), and serving more than one story."

Exception Number One:

"Return system smoke detectors are not required when the entire space served by the air distribution system is protected by a system of area smoke detectors." (NFPA 90A, 2002, 6.4.2.2)

Exception Number Two:

"Fan units whose sole function is to remove air from inside the building to outside the building." (NFPA 90A, 2002, 6.4.2.3)

Application Documents

There are several important documents that provide guidance concerning the performance, application and installation of duct smoke detectors:

- U.L. Standard 268A, Standard for Smoke Detectors for Duct Applications
- NFPA Standard 90A, Installation of Air Conditioning and Ventilating Systems
- NFPA 92A, Standard for Smoke-Control Systems Utilizing Barriers and Pressure Differences
- NFPA 92B Standard for Smoke Management Systems in Malls, Atria, and Large Spaces
- NFPA Standard 72, National Fire Alarm Code
- NFPA Standard 101, Life Safety Code
- ASHRAE Handbook and Product Directory, "Fire and Smoke Control"

Typical Scenarios

Duct smoke detection may be useful in preventing injury and property damage in instances such as the following:

A heating, ventilating, or air conditioning (HVAC) fan motor overheats and resulting smoke is sensed by the duct smoke detector installed in the main supply duct. The duct smoke detector is equipped with an auxiliary relay that immediately cuts power to the fan motor before significant amounts of smoke can be distributed to the occupied areas.

Refer to NFPA, 2007 6.16.5, 90A, Standard for the Installation of Air-Conditioning and Ventilation Systems and NFPA 92B, Standard for Smoke Management Systems in Malls, Atria, and Large Spaces.

¹ NFPA 90A-2002, Appendix A 6.4

² NFPA 90A-2002, Section 6.4.2.1

Section 2
Characteristics of Smoke in HVAC Systems

Since the primary purpose for detecting smoke in the HVAC system is to automatically initiate action to minimize the spread of smoke through the air handling system, it follows that the nature of the smoke to be expected in various parts of the system should be understood. The following discussion is a theoretical description of smoke characteristics as they pertain to this application, as yet, not supported by fire test data.

Smoke

Smoke, as defined in NFPA 72, Section A.5.14.4.2, is “the totality of the airborne visible or invisible particles of combustion.” Smoke detectors are designed to sense the presence of particles of combustion, but depending on the sensing technology and other design factors, different detectors respond to different types of particles. Detectors based on ionization detection technology are most responsive to smaller, invisible sub-micron sized particles. Detectors based on light scattering technology, by contrast, are most responsive to the larger visible particles. Detectors based on light extinction technology respond to both visible and invisible particles Figure 1 shows the relative sensitivity of the three technologies as a function of particle diameter, assuming a constant mass of particles.

It is generally accepted that particle size distribution varies from sub-micron diameter particles predominant in the proximity of the flame of a flaming fire, to particles one or more orders of magnitude larger, characteristic of smoke from a smoldering fire. The actual particle size distribution depends upon a host of other variables including the fuel and its physical makeup, the availability of oxygen including air supply and fire gas discharge, and other ambient conditions, especially humidity. Moreover, the particle size distribution is not constant; as the fire gases cool, the sub-micron particles agglomerate and the very large ones precipitate. In other words, as smoke travels away from the fire source, the particle size distribution shows a relative decrease in smaller particles. Water vapor, which is abundantly present in most fires, when cooled sufficiently will condense to form fog particles—an effect frequently seen above tall chimneys. Since water condensation is basically clear in color when mixed with other smoke particles, it can be expected to change the color of the mixture to a lighter one.

From the above discussion, one can begin to get an idea of what “smoke” is in the various parts of an air handling system. Specifically, the farther away the point of observation from the fire source, the cooler the smoke will be and the more visible because of the growth of sub-micron particles by agglomeration and recombination. There probably is some loss in quantity, i.e., the mass of the smoke particles at the point of entry to a duct system is probably greater than at some finite point downstream. However, at concentrations of concern, losses by precipitation are probably negligible.

Change in Concentration

A much more important consideration is the change in concentration because of dilution by clean air from other return air ports in the duct system. A simple mathematical consideration will show that the original concentration is given by Q/V where Q is the quantity of smoke particles and V the volume in which they are dispersed. If a return duct has four

branches, each with equal air flow (cfm), then after they join, the concentration will be reduced to $Q/4V$.

The preceding assumes uniform dispersion of particles which represents an ideal condition. In reality there is non-uniform dispersion and concentration can and does vary from no smoke to a very high concentration of smoke in a cross-section area of a duct. This is especially true just downstream from any point of entry. In a return air duct, for example, stratification can be expected immediately downstream from each return air grill. Text books teach that uniform dispersion is reasonably assured at a distance equal to 10 duct widths downstream for a duct with turbulent air flow. In those cases where stratification is predominant, uniform dispersion might never be achieved.

Air velocity has no direct effect upon the characteristics of smoke. It does affect the concentration because as velocity is increased, the total volume of smoke being produced and dispersed at some rate, Q/dt (the quantity of smoke per given time period), increases proportionately. Stated differently, in a one-foot square duct an air velocity of 100 feet per minute would transport 100 cubic feet of air each minute. Increasing the velocity to 400 feet per minute would increase the volume of air transported to 400 cubic feet per minute, thereby reducing the concentration of smoke particles by a factor of four, assuming that the rate of smoke generation was the same in both cases.

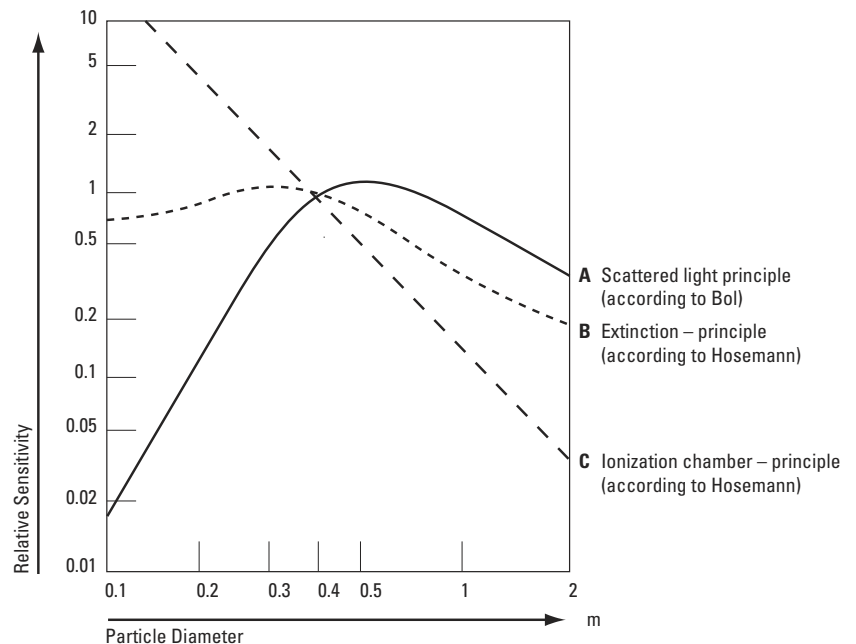

Figure 1: Relative Sensivities of Three Technologies as a Function of Particle Diameter (Source: NBS IR78-1502, “Smoke Measurements In Large and Small Scale Fire Testing,” by Richard W. Bukowski)

Section 3
Duct Smoke
Detection Equipment

A duct smoke detector is a device or group of devices used to detect the presence of smoke in the airstream of ductwork sections of the HVAC air handling systems typically used in commercial buildings.

Typical smoke detection devices used for duct application include smoke detector sensors within a housing mounted outside the duct utilizing sampling tubes (Figure 2), area smoke detectors listed for in-duct or partial in-duct mounting, a light beam detector consisting of projector and receiver mounted within the duct, and an air sampling type detector. In all cases, alarm contacts are available either in the detector or in the fire alarm control unit to initiate air movement control or to perform other control functions.

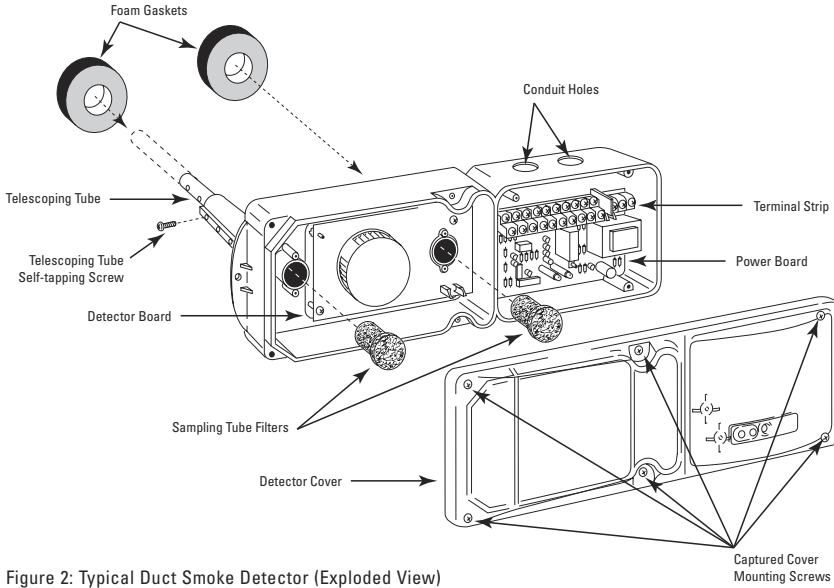

Figure 2: Typical Duct Smoke Detector (Exploded View)

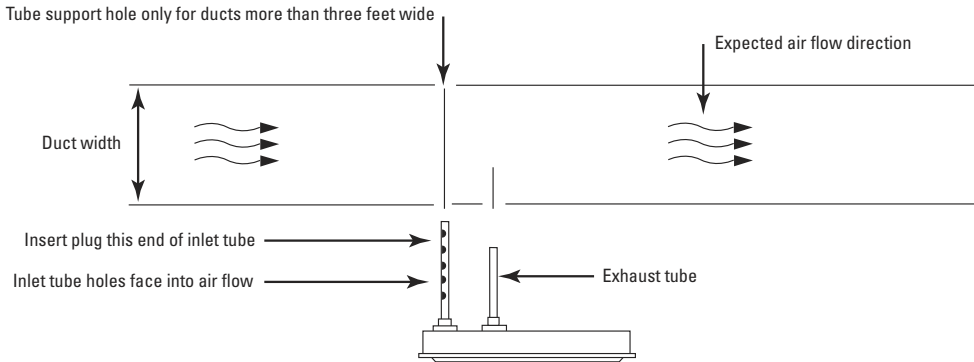

Figure 3: Typical Installation Using Air Sampling Tubes

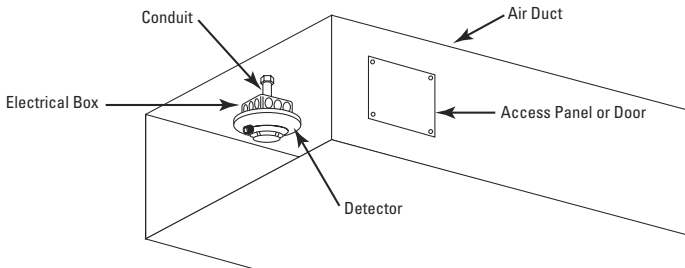

Figure 4: Pendant Mounted Air Duct Installation

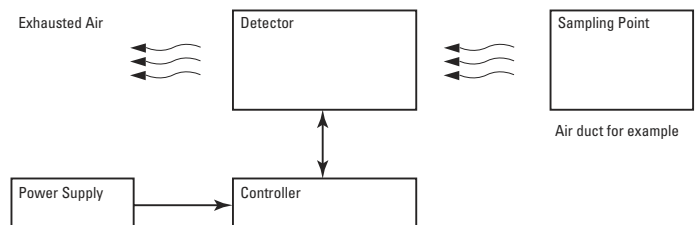

Figure 5: Typical Air Sampling Detector Installation

An externally mounted duct smoke detector enclosure may incorporate either an ionization or photoelectric type smoke sensor. Air stream sampling is accomplished by sampling tubes that penetrate and traverse either the supply or return air ducts. The sampling tubes are positioned so air may be drawn through the detector, sampled, and then returned to the air stream in the duct (Figure 3).

An area smoke detector, listed for the application, may be mounted on an outlet box totally within the duct or they may be mounted on the exterior of the duct, with the sensing area of the detector protruding into the air stream (Figure 4).

Another duct detection device may be the light beam type detector. This unit performs best when utilizing long beam paths, e.g., in the large plenums rather than small ducts.

Air sampling detection units are extremely sensitive and can detect minute changes in air particle concentration (Figure 5). An air sampling detection tube or head is inserted in the air stream of the duct. Air is drawn out and through the detection device. The detection unit typically is set at an operating level of normal background particle concentration. An alarm will sound when the concentration exceeds a preset alarm threshold value.

Section 4
Typical Air Handling Systems

Heating, ventilating and air conditioning systems, as applied to commercial buildings, condition and distribute

air usually through a network of ducts. The air handling system can be divided into four basic sections: mixed air, conditioning, fan, and terminal. Figure 6 shows a simplified schematic view of a typical air handling system.

Mixed Air Section

This section consists of a plenum where recirculated (return) air and fresh (outside) air are introduced and mixed. A filter removes dirt, dust and other airborne particles from the air before it enters the conditioning section.

Conditioning Section

The conditioning section generally consists of a heating coil, a cooling coil, a humidifier or any combination thereof. These coils may be arranged in series, in parallel, or in a combination of series and parallel.

The cooling coil lowers the temperature of the air passing through either by using chilled water or direct expansion of a refrigerant gas supplied from a remote refrigeration compressor.

The heating coil raises the temperature of the air passing through it by means of steam, hot water, or electric heaters. Humidifiers add moisture in the form of dry steam directly into the air stream. A humidifier is shut off whenever the system supply fan is not running to avoid moisture damage to the duct system.

Fan Section

This section consists of one or more fans powered by a single electric motor. The fan section may be placed before or after the conditioning coils.

The fan section may include a device to regulate the static pressure developed by the fan. This device might be an inlet vane (vortex) damper, discharge damper, suction damper, or a device to regulate the fan speed.

Terminal Section

This section controls the volume or the final conditioning of the air before it is supplied to the conditioned space. Sometimes terminal devices are located in the same mechanical equipment room that houses the air handler. More often, terminal devices are located remote from the individual spaces that they serve. These terminal devices can be reheat coils, mixing boxes, variable volume boxes and induction units.

Key Parameters

The capacity of air handling systems are typically rated in cfm (cubic feet per minute). This is determined by multiplying the cross sectional area of the duct in square feet times the velocity of the air in feet per minute. (Note for a metric system the capacity is rated in cubic meters per second.)

Air velocities used in duct systems are typically 500 ft/m (2.54 m/s) which is the rating for most of the heating and cooling coils used in the systems. Higher velocities may be encountered in applications where air must be moved through longer ducts. Maximum velocities encountered there can be

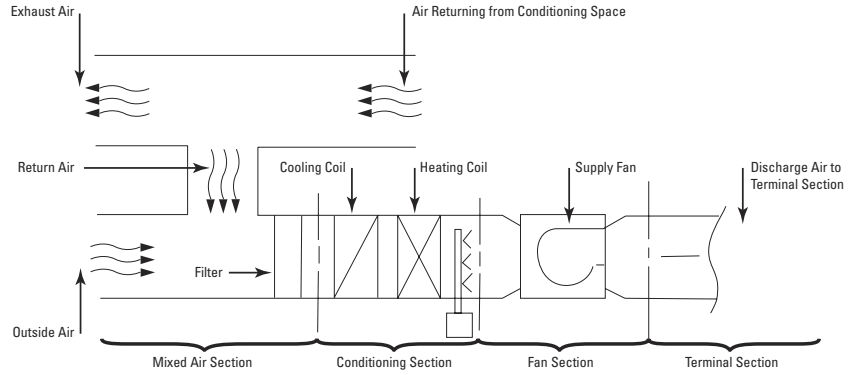

Figure 6: Typical Air Handling System

as much as 4500 ft/min (22.9 m/s). The air velocity in the supply (fan discharge) side will be larger than in the return side. Velocities in the return side may be as low as 200-300 ft/m (1.02 – 1.52 m/s).

The range of sizes in duct work varies greatly. The smaller ducts are similar in size to the air ducts used in a residential dwelling and may be less than 1' x 1' (.3 m x .3 m). The maximum duct sizes used in large air handling systems are the following:

System Type	Supply Side	Return Side
High Pressure	8' x 8' (2.78 m x 2.78 m)	Can be very large, 12' x 12' (4.18 m x 4.18 m) or more
Low Pressure	6' (2.09 m) diameter	Can be very large, 12' x 12' (4.18 m x 4.18 m) or more

The air pressure inside a duct with respect to the air pressure outside the duct is positive on the supply side of the fan and is negative on the return side.

Pressure in Inches H₂O (kPa)*

System Type	Supply Side Max In	Supply Side Typical	Return Side Max In	Return Side Typical
High Pressure	+5 (1.24)	+4.0 (.99)	-2 (.50)	-1 (.25)
Low Pressure	+2 (.50)	+1.5 (.37)	-2 (.50)	-1 (.25)

*(1" H₂O = .2486 kPa)

The temperature inside the duct of an operating air handling system is between 42°F and 180°F (5.6°C and 82.2°C). Cooling applications have the lowest temperatures. For heating applications, the typical temperature is about 100°F (37.8°C). The 180°F (82.2°C) temperature is unusual and is encountered only in areas near a steam coil. When the fan is off, temperatures in the vicinity of a steam coil may reach 240°F (115.6°C). A device located here may be even warmer due to radiation from the steam coil.

The temperature of the air in the mixed air and outside air sections are affected by the outdoor temperature. In very cold climates, the temperature in these sections can be as low as -40°F (-40°C).

The expected temperature range surrounding the duct system is as shown below:

Indoor areas	Outdoor areas
45°F to 120°F	-40°F to 160°F
(7.2°C to 48.9°C)	(-40°C to 71.1°C)

Section 5
How Duct Detection Systems Are Used to Control Smoke

An HVAC system supplies conditioned air to virtually every area of the building. Smoke detectors designed for use in air duct systems are used to sense presence of smoke in the duct.

NFPA 90A

NFPA 90A, "Standard for Air Conditioning and Ventilating Systems", requires that smoke detectors listed for duct installations be installed at a suitable location in the main supply duct on the downstream side of the filters to automatically stop the supply fans in systems over 2,000 cfm. For systems over 15,000 cfm an additional detector is required in the return duct or plenum of each floor, at the point of entry into the common return, or a system of spot type smoke detectors is required to provide total area coverage. (Note: Users of this manual should refer to NFPA 90A for more information on smoke control requirements.) The International Mechanical Code and other codes require a duct detector in the return for units over 2000 cfm and requires a detector in the supply duct for systems over 15,000 cfm. Many designers require duct detectors in the supply and return in an attempt to meet

both conflicting requirements. In order to obtain a representative sample, HVAC areas with stratification and dead air space should be avoided. Duct smoke detectors should be located in the HVAC area between 6 and 10 duct-equivalent diameters of straight, uninterrupted run.

Typical Single Zone HVAC System

Figure 7 shows a typical single zone HVAC system. A return air fan is not used in all systems. Detectors may be placed in the outdoor air supply to sense if smoke is being drawn into the system from outside of the building. It would then close the outdoor air damper allowing the rest of the HVAC system to continue operating.

In the typical fan system shown in Figure 7, when any duct smoke detector senses smoke, the fan system will be turned off and all the dampers shown will go to their closed positions. These actions are intended to prevent smoke from being distributed via the air handling system to unaffected areas of a building.

An alternate method that may be used is to only stop the supply fan and keep the return fan running. In this method

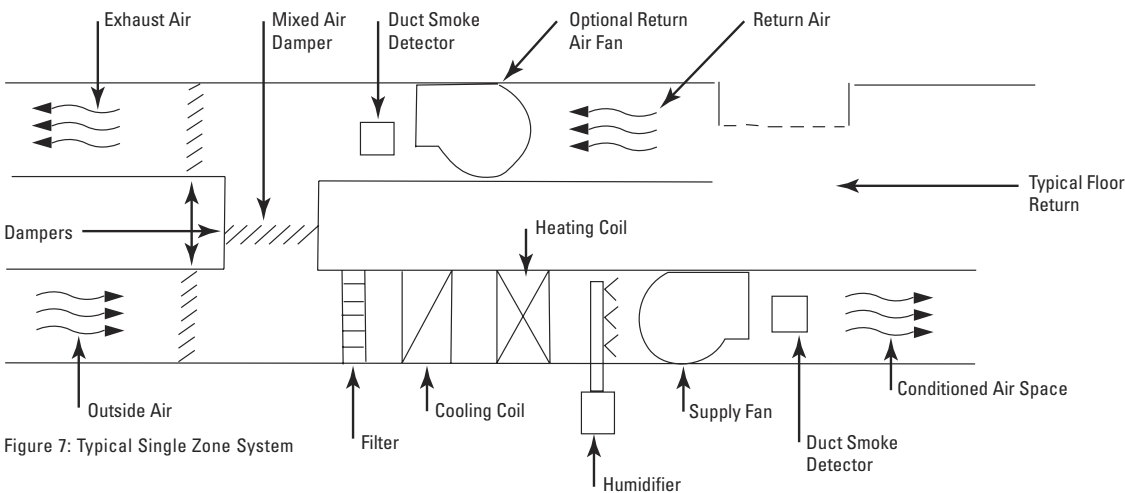

Figure 7: Typical Single Zone System

the outdoor air damper and the mixed air damper go closed and the (exhaust) air damper is opened. This technique will help exhaust smoke-laden air from the building. In addition to the requirements of NFPA 90A, duct smoke detectors may also be used within duct systems as detection devices in engineered smoke control systems. These systems are engineered for the specific building. They use the building construction and air handling systems to contain and reduce the spread of smoke.

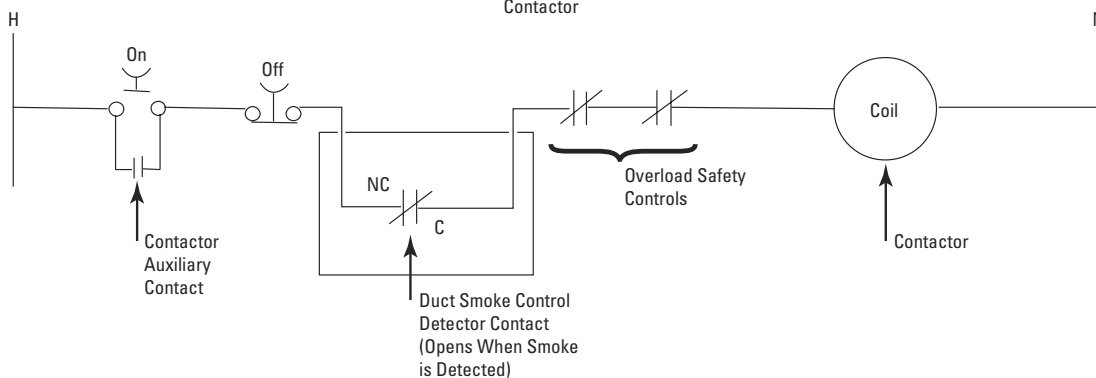
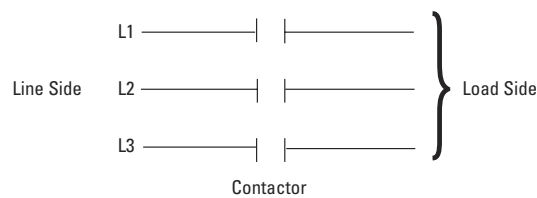

Figure 8: Typical Fan Control Shut Down Circuit

NFPA 90A¹ requires that when there is an approved fire alarm system installed in a building, required duct smoke detectors must be connected to the fire alarm system so that activation of any duct smoke detector will cause a supervisory signal to be indicated at a constantly attended location, or will cause an alarm signal.

Typical Fan Control Circuit

Figure 8 shows a typical fan control circuit.

¹ NFPA Standard 90A-2002, Section 6.4.4.2

Section 6
Procedure for Duct Smoke Detector Application and Installation

Application
 Select supply and exhaust ducts to be monitored by smoke detectors.¹

Locate supply or exhaust input/output ports, filters, diluters, dampers, chillers, heaters, humidifiers, dehumidifiers, air cleaners, control devices, deflectors, bends and restrictors in engineering drawings and specifications.

Supply duct smoke detector installation should be downstream of fans, filters, chillers, heaters, and humidifiers.

Duct smoke detectors in the return air stream should be located at every return air opening within the smoke compartment, or where the air exits each smoke compartment, or in the duct system before air enters the return air system common to more than one compartment.

Exception: Additional smoke detectors are not required in ducts where the air duct system passes through other smoke compartments not served by the duct.

Location of detectors mounted in or on air ducts should be downstream from any duct openings, deflection plates, sharp bends or branch connections.

Exception: Where it is physically impossible to locate the detector accordingly, the detector can be positioned where pressure differentials are within those established by the manufacturer for the proper operation of the detector, usually as far as possible from the opening, bend or deflection plates.

Upon selection of the location for duct smoke detector installation, drill a hole into the duct and measure duct air velocity, humidity, and temperature. Refer to duct instrumentation for instrument use in this manual (pages 8-9).

Measure room temperature and humidity in the area of intended duct smoke detector installation.

Detectors should be listed by a third party testing laboratory for the environment measured in the duct and room at the installation site. Relocate the detector if measurements fall outside of rated limits.

Installation

Installation of duct smoke detectors may be within the duct, protruding into the duct, mounted in an enclosure with sampling tubes protruding into or traversing the duct.

Drill only required holes for duct installation. A template specifying hole diameters or entry dimensions should be provided to locate mounting holes for detector enclosure, sampling tubes, access panels, or doors.

Detector installation within the duct can be of the pendant or beam type.

The pendant duct smoke detector should be mounted to an appropriate electrical box. The box pendant extension arrangement should be mounted from either the top or side walls extending to the center of the air duct stream.

An access panel or door is incorporated in the duct side walls and is used during installation and for maintenance and test.

A pendant detector arrangement should be mounted rigidly to withstand the pressure and resonant vibrations caused by the air velocity. (See Figure 9.)

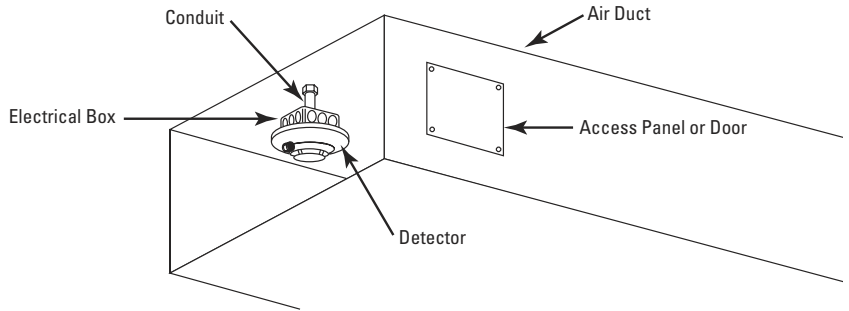

Figure 9: Pendant Mounted Air Duct Installation

Following are procedures that aid in properly installing smoke detectors that mount to the side of the duct and sample smoke by means of tubes that project into the duct.

A well placed duct smoke detector monitors representative samples of air flowing through a duct. While any air sample may seem sufficient, there can be several problems:

Dilution: If outside air mixes with circulated air, it can dilute combustion particle concentration and prevent a detector from sensing a fire. Remember that detectors alarm only when combustion particles constitute a specified percentage of air being sampled. To avoid dilution, detectors should be located before fresh air intakes and before the exhaust air output.

Stratification: Detector placement should be such that there is uniform air flow in the cross section area. In practice, this ideal condition may not always be achievable. The distance from a bend or vent is usually given as a multiple of duct width or diameter. Within a duct, air and combustion particles may stratify in such a way that proper sampling cannot take place. The wider the duct, the greater the possibility of stratification taking place. A method of getting a representative air sample is to locate a duct smoke detector directly after a bend in the duct after an air inlet which creates turbulence (See Figure 10). A distance of 6 duct widths should separate the duct housing from the bend or inlet. (See Exception noted above under “Application”.)

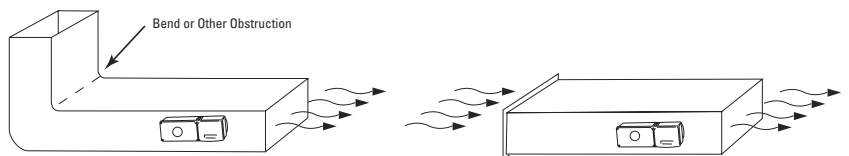

Figure 10: Typical Duct Smoke Detector Placement

¹ See NFPA 90A for details of where duct smoke detectors can be eliminated in systems with air flow greater than 2,000 cfm capacity or in buildings equipped with a system of smoke detectors providing total area coverage.

Excess Humidity: As with open area detectors, high levels of humidity or condensation within the duct can cause false alarm problems. Duct smoke detectors should be located at a minimum of 10 feet downstream from humidifiers.

Air Filters: Air filters within ducts tend to collect paper, lint and trash — all flammable materials. For this reason, duct smoke detectors should be located on the downstream side of filters.

Air Velocity: Duct smoke detectors are usually designed to be used in air handling systems having a certain range of air velocities. Be sure to check engineering specifications to make sure duct air velocity falls within these parameters.

Placement: Duct smoke detector assemblies mounted within the duct should be located on the sides or top of a duct. Detectors listed for use in open air applications should not be used inside a duct in place of a duct smoke detector.

Duct smoke detectors mounted in an enclosure with sampling tubes can be installed onto any wall of the duct unless otherwise restricted by the manufacturer’s instructions.

Select the proper sampling tube length for duct enclosure installation. If duct is more than three feet wide, drill an appropriate diameter hole directly opposite but two to three inches lower to support the sampling tube of lengths longer than three feet.

Exhaust tube length is not usually a critical dimension. It may vary from a stub to the full width of the duct. Be sure to follow the recommendations of the manufacturer regarding the exhaust tube.

Install the sampling and exhaust tubes to the mounting holes on the duct enclosure.

Tubes may be marked or, as indicated in manufacturer’s installation instructions, provided with inhibitors to ensure that the tubes are installed in their proper duct input and output ports.

Position holes or openings located along the length of the sampling tube into the air flow. Secure tube position with

locking means provided. A tube visual indicator should be provided to indicate the tube hole location without dismantling the duct installation.

Plug sampling tube end with an air stopper.

The duct smoke detector enclosure and sampling tubes should be mounted rigidly to prevent noise chatter and mechanical fatigue.

Avoid air leaks. Air leaks in or out of the duct or detector dilute or redirect smoke within the duct. Gaskets and duct seal can be used to avoid or seal any leaks.

If duct sampling tube protrudes through opposite side of duct, seal the opening around the tube on the outside of the duct with duct sealant.

After mounting the duct enclosure to the duct and installing the sampling and exhaust tubes, verify that there is air flow through the duct smoke detector. This is accomplished by measuring the static pressure difference between the inlet and outlet tubes using a manometer as illustrated in the instrument section of this manual. If pressure differential cannot be attained, check for leaks, proper orientation of hole placement on sample tube, air velocity, and stratification of airflow in the duct. Relocate the duct smoke detector if the pressure differential specified by the manufacturer cannot be attained after checking all possible fault causing problems.

Prior to completing the installation, clean the duct enclosure, and check indicators for hole orientation.

Duct Instrumentation

Pressure Reading Instruments

Used for reading:

- Air velocities in ducts
- Pressure drops across components

Instrument readings taken by:

- Inclined liquid manometer
- Vertical liquid manometer
- Pressure differential gauges
- Micrometer liquid hook gauge

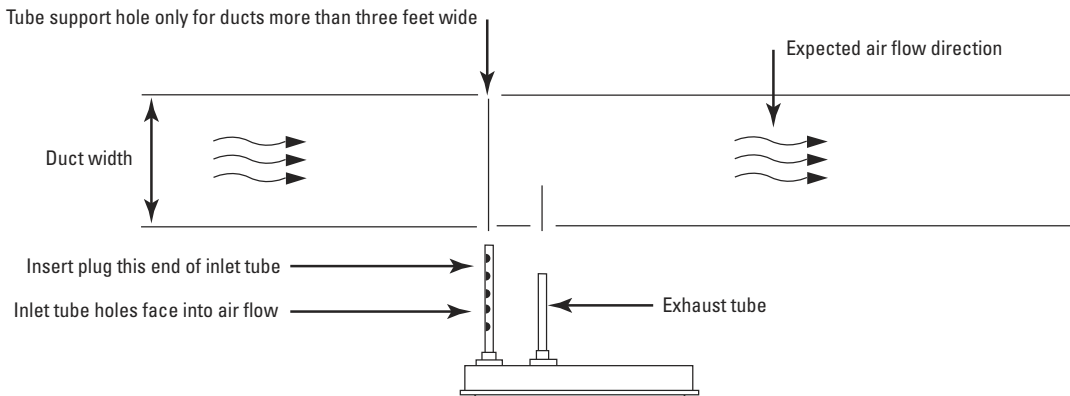

Figure 11: Inlet Tube Orientation

Manometer gauges are used in conjunction with pitot tubes, straight metal tubes and various static pressure sensors.

gauge use. See Figure 13 for manometer type, and Figure 14 for magnehelic gauge.

Pressure drops are best read with a magnehelic gauge. For lower velocity readings in the range between 400 and 2000 fpm a 1/4-inch manometer is the most accurate instrument to use along with the pitot tube. For higher velocity readings in ducts, the 10-inch vertical or the one inch inclined manometer is required. See Figure 12 for example of manometer and

Air Velocity Reading Instruments

Used for reading:

- Air flow through duct openings
- Air flow through duct filters, coils, louvers

Instrument readings taken by:

- Velometer
- Thermo-Anemometer (see Figure 15)

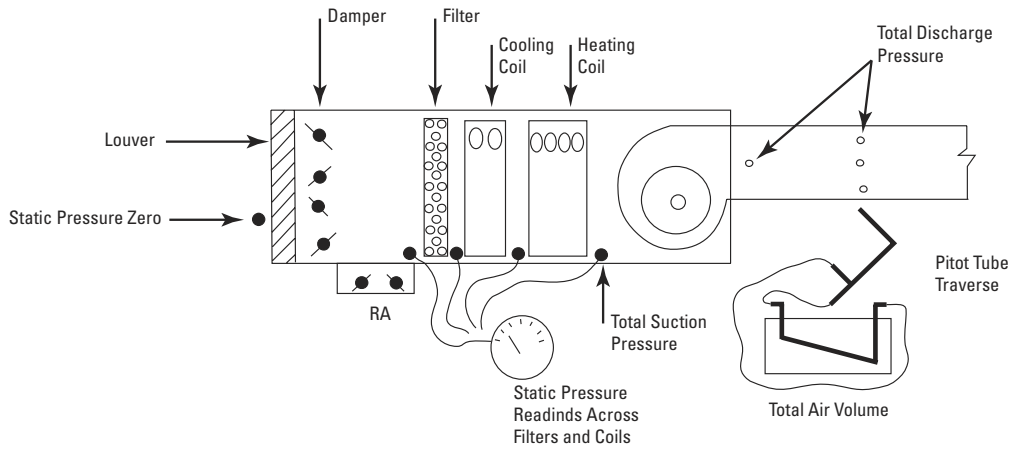

Figure 12: After electrical and fpm readings are taken, the total volume of air, fan pressure and pressure drops are read.

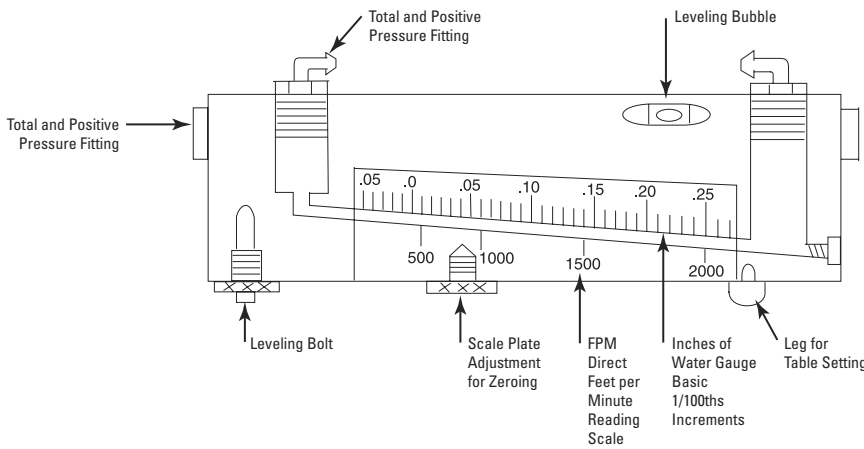

Figure 13: 115-AV inclined manometer for velocity pressure readings in low velocity ducts, 400 to 2000 fpm.



Figure 14: Magnehelic gauge for reading static pressures in air systems



Figure 15: Thermo-Anemometer

Section 7
Maintenance and Service of Detectors for Use in Ducts

Sensitivity; this is especially true with duct type smoke detectors. They can become more sensitive, which may cause unwanted alarms, or less sensitive, which may reduce the level of protection. Both are undesirable. Therefore, detectors should be tested periodically and maintained at regular intervals. Follow closely the manufacturer’s specific recommended practices for maintenance and testing. Also refer to Chapter 10 of NFPA 72, 2007.

Typical Maintenance Practices

Under normal conditions detectors require routine maintenance annually, but harsher environments may require an increased maintenance schedule.

Notify the proper authorities that the smoke detector system is undergoing maintenance; therefore, the system will be temporarily out of service.

CAUTION

Disable the zone or system undergoing maintenance to prevent unwanted alarms and possible dispatch of the fire department.

Most duct smoke detectors have detector sensors that can be accessed for cleaning. Use a vacuum cleaner and remove dust from the detector by placing the nozzle as close as possible to the openings in the outside housing. A nozzle with a brush attachment will assist in dust removal. Some detectors can be removed for more thorough cleaning; refer to manufacturer’s recommended procedure for details. Also check the sampling tube holes to make sure they are not clogged.

Test each detector’s sensitivity.

If a detector’s sensitivity is within specifications, nothing further needs to be done to the detector. If the detector’s sensitivity is outside specifications, replace the detector or follow the manufacturer’s recommended procedure.

Restore the zone or system at the completion of testing.

Notify the proper authorities that testing has been completed and the system is back in service.

Smoke detectors are designed to be as maintenance-free as possible. However, dust, dirt, and other foreign matter can accumulate inside a detector and change its sensitivity;

Other maintenance checks :

- Holes or cracks in duct work near vicinity of detector.
- Air leaks where detector housing or sampling tubes are attached to duct.
- Dust accumulations in or on sampling tubes, sampling tube filters, and detector head.
- Wiring terminal screw tightness.

Typical Testing Procedures

All detectors should be:

- (a) Tested or inspected at least annually to ensure that they sample the air stream.
- (b) Tested at least annually causing them to initiate an alarm at their installed location to ensure that they are operative and produce the intended response.
- (c) Checked within one year after installation and every alternate year thereafter to assure that they are within their listed and marked sensitivity range.

It is not recommended that duct fires be used to test duct smoke detectors. This procedure does not provide a consistent, measurable method of determining if the detectors are performing properly. The test procedures and test equipment recommended by the detector manufacturer are the best way to test these detectors.

Most detectors are equipped with a built-in test mechanism, electronic metering equipment, or aerosol test apparatus. Refer to manufacturer’s specifications for details.

Notify the proper authorities that the smoke detector system is being tested. All persons who would automatically receive a real fire alarm signal should be notified to prevent an unnecessary response.

Follow the manufacturer’s recommended test methods.

If a detector functions properly and its sensitivity is within specifications, nothing further need be done to the detector. However the routine maintenance procedure described under “Typical Maintenance Practices” above is recommended. If a detector’s sensitivity is not within specifications, it should be replaced, or refer to manufacturer’s recommended procedure.

Restore the zone or system at the completion of the testing.

Notify all the persons contacted at the beginning of the test that testing has been completed and the system is again operational.

Recommended Testing and Maintenance Log Procedures

It is recommended that a permanent Detector Test Log be set up and maintained, with a record for each individual smoke detector in each building. Each detector should be clearly

described with information on the type of detector, the model number, the serial number (if any), the location, and the type of environment. Data entries should include test dates, type of test mode, test results, maintenance, and comments. A sample detector test log page is shown below.

Detector Test Log

Detector Identification Information

Manufacturer and Detector Model:

Serial Number:

Date Installed:

Description of Detector Location:

Example: 3rd floor of west wing in elevator lobby.

Test Results and Maintenance Data

Date Tested	Test Mode	Test Results	Maintenance Performed and Comments
<i>Example:</i>	<i>detector test button</i>	<i>passed</i>	<i>none</i>

Section 8

Glossary of Terms

Air Sampling Detector

An extremely sensitive smoke detection device that can sample, test and evaluate the amount of particle concentration within an air sample.

Area Smoke Detector

A device that will detect visible or invisible particles of combustion. Also called a spot type detector.

Coil

A cooling or heating element made of pipe or tubing.

Coil, direct expansion

Coil using the direct refrigeration method.

CFM

Unit volume of air flow — Cubic Feet per Minute.

Damper

A valve or plate regulating the flow of air or other fluid.

Damper, multiple louver

A damper having a number of adjustable blades, used to vary the volume of air passing through a confined section by varying the cross sectional area.

Duct

A passageway made of sheet metal or other suitable material not necessarily leak-tight, used for conveying air or other gas at low pressures.

Duct Smoke Detector

A device located within the duct, protruding into the duct, or located outside the duct that detects visible or invisible particles of combustion flowing within the duct. Actuation of the device may allow operation of certain control functions.

Exhaust Tube

Usually a round tube that provides a path for sampled air to return from the detection device to the duct.

Fan

An air moving device comprising a wheel or blade and a housing or orifice plate.

FPM

Unit velocity of air flow — Feet Per Minute.

Humidifier

A device to add moisture to the air.

Inch of Water

A unit of pressure equal to the pressure exerted by a column of water at a temperature of 4.0°C (39.2°F).

Inlet Sampling Tube

Usually a round tube with holes that collects air from the duct and brings it to the detection device.

Ionization Detector

A smoke detector using the principle of ion flow within a chamber to detect visible and invisible particles of combustion (within a size range normally encountered as a result of fire).

Light Beam Detector

A smoke detection device that operates on the smoke obscuration principle.

Magnehelic Gauge

Gauge for reading static pressures in air systems.

Photoelectric Detector

A smoke detector using the principle of optical detection of visible particles of combustion.

Pitot Tube

A device used to measure the total pressure of a fluid stream. It is essentially a tube attached to a manometer at one end and pointed upstream at the other.

Pressure

The normal force exerted by a homogenous liquid or gas per unit of area on the wall of a container.

Pressure Differential

A pressure difference (usually specified in inches of water) between two points in a duct.

Return Exhaust

The duct which is used to return the air to the HVAC processing center for conditioning.

Sampling Tube

Usually a round tube with holes that collects air from the duct and brings it to the detection device.

Smoke Detector

A device used to automatically sense the presence of particles of combustion.

Stratification

A phenomenon where smoke or other gases travel in layers at different levels within the duct, rather than being evenly distributed throughout the duct.

Supply Duct

The duct which distributes conditioned air, i.e., cooled, heated, cleaned, humidified, etc.

Thermo-anemometer

A device used to measure air velocity.

Venturi Principle

A tube with a narrow throat (a constriction) that increases the velocity and lowers the pressure of the liquid or gas passing through it, creating a partial vacuum immediately after the constriction in the tube. The vacuum created has a sucking effect (eduction), and a Venturi is commonly used to introduce a liquid (such as a regenerant) or gas (such as air) into a flowing water stream.



advanced ideas. advanced solutions.™

8 0 0 / 7 3 6 - 7 6 7 2
www.systemsensor.com