

Extreme Wind Condition Mounting Kit

INSTALLATION INSTRUCTIONS

For Anchoring (*)P3R(*), (*)P5R(*), (*)P7R(*), PPA1R(*), PPA2R(*), PPA3R(*), TARG - AC Models & (*)Q3R(*),(*)Q5R(*), (*)Q7R(*), PPH1R(*), PPH2R(*), PPH3R(*), TPRG - HP Models

KIT CONTENTS

DESCRIPTION	QUANTITY
Base Mounting Bracket for models with metal base pan	4
Tapcon™ Concrete Screw 1/4" x 1-3/4"	4
Installation Instructions	1

ABOUT THE KIT

The extreme wind condition mounting kit is used to anchor Nordyne small packaged air conditioners and heat pumps.

This anchor system is designed to meet the requirements of Section 1620 of the Florida Building Code, 5th Edition (2014), regarding the wind resistance and anchoring requirements for mechanical equipment in Florida hurricane zones. This kit will secure these units to an adequately designed concrete base pad so that it can withstand a 3 second gust of a maximum wind speed of 180 MPH. Minimum concrete pad requirements are shown in the illustration.

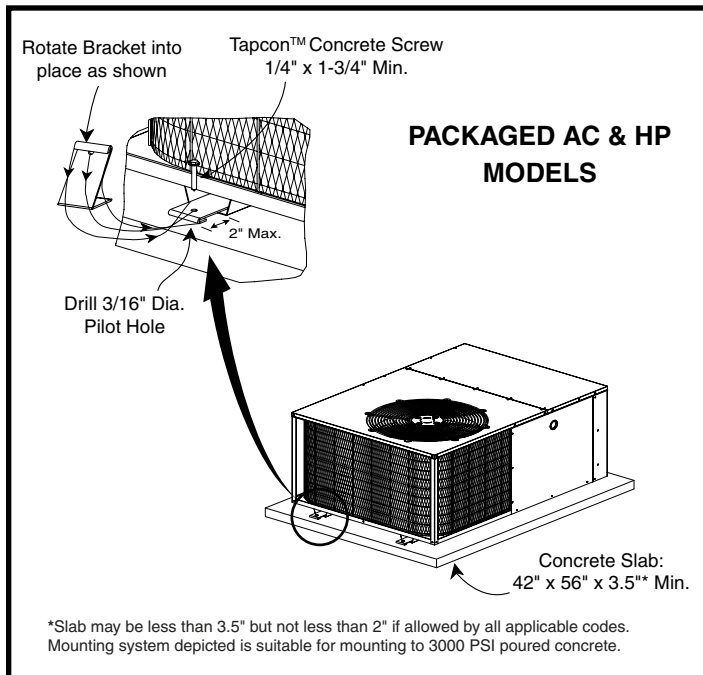

INSTALLATION OF THE ANCHOR KIT ON SPLIT-SYSTEM AC/HP MODELS:

1. It is recommended that this kit be installed on the unit prior to connecting refrigerant lines and electrical wiring. It may be installed later if necessary.
2. Position the unit on the concrete pad and install the base mounting brackets as shown in the figure below. **NOTE:** The provided concrete screws may be used if the unit is being anchored to a concrete pad or slab.
3. Install one anchor in the end of each base rail as shown in the figure below. **IMPORTANT:** The screws used in this kit must be properly installed so that the head of the fastener engages the bracket and anchors it securely.

PRODUCT CERTIFICATION

The test data, instructions, and contents of the "High-Wind" mounting kits for anchoring Model (*)P3R(*), (*)P5R(*), (*)P7R(*), (*)Q3R(*), (*)Q5R(*), (*)Q7R(*), PPA1R(*), PPA2R(*), PPA3R(*), PPH1R(*), PPH2R(*), PPH3R(*), TARG & TPRG packaged units have been reviewed and these findings have been established:

- The mounting kit clips allow the designated units to resist a 180 MPH wind speed when fastened to an adequately designed hard concrete in accordance with provided instructions.
- The acceptable anchoring fasteners include 1/4" Tapcons™ with 1 1/2" embedment into concrete.
- The technical study was based upon Section 1620 of the Florida Building Code, 5th Edition (2014), 3 second gust wind speed, and an exposure category "C".

NOTE: Copies of the Installation Instructions included with the kit are not stamped. If the local Mechanical Inspection office does not have a stamped copy of this Installation Instruction on file, one may be obtained from the manufacturer of this kit. Contact the distributor where this kit was purchased.



EACH OF THE UNITS LISTED BELOW CONFORM TO THE REQUIREMENTS OF THE 5TH EDITION OF THE FLORIDA BUILDING CODE (2014) AND ASCE 7-10. IF THE HIGH WIND KIT IS PROPERLY INSTALLED THE UNIT WILL REMAIN FASTENED TO THE SLAB AND WILL ALSO NOT LOSE IT'S STRUCTURAL INTEGRITY AND BECOME WINDBORNE DEBRIS IF EXPOSED TO THE FOLLOWING CONDITIONS:

The covered units are all less than 35 inches wide, less than 62 inches long, less than 38.2 inches tall, and less than 443 pounds in weight.

Ultimate design wind speed (3 second gust) = 180 MPH

Maximum height of unit installation = 60 feet

MODEL NUMBER
(*)Q5RF SERIES
PPH2RF SERIES
(*)Q7RE SERIES
PPH3RE SERIES
TPRG SERIES
(*)P5RF SERIES
PPA2RF SERIES
(*)P7RE SERIES
PPA3RE SERIES
TARG SERIES
(*)Q5RD SERIES
PPH2RD SERIES
(*)Q7RD SERIES
PPH3RD SERIES
(*)P5RD SERIES
PPA2RD SERIES
(*)P7RD SERIES
PPA3RD SERIES



Coefficient Definitions
FBC Ref.

1620.2	Ultimate design wind speed (mph)	V_{ult}	180	Risk Category II	
1609.3.1	Nominal design wind speed	V_{asd}	139		
1609.4.3	Exposure Category	C			
1609.6.2	Wind Stagnation Pressure	q_s	82.94		
1609.6.4.2	velocity pressure exposure coefficient	K_z	=	$2.01((z/z_g)^{2/a})$	= 1.14
	height above ground (ft)	z	60		
		z_g	900		
		a	9.5		
1609.6.4.2	Topographic factor*	K_{zt}	=	$(1+(K_1*K_2*K_3))^3$	= 1.06
	Height of Hill (ft)	H	60		
	Distance upwind of crest to half hill height (ft)	L_h	30		
	Distance from the crest to the building (ft)	x	90		
	Height above local ground level (ft)	z	27		
	*worst case				
		K_1	0.72		
		K_2	0.25		
		K_3	0.11		

6.5.3(6) ASCE 7 Enclosure Classification Partially Enclosed

1609.6.4.3	Net Pressure Coefficient	$C_{net,h}$	1.05	Windward Wall
		$C_{net,v}$	-0.97	Partially Enclosed Flat Roof
		$C_{net,leeward}$	-0.83	Leeward Wall
		$C_{net,sidewall}$	-0.97	Sidewall

1609.6.3	Wind Pressure (psf)	$P_{net,horiz}$	=	$q_s * K_z * C_{net,h} * K_{zt}$	= 105
		$P_{net,vert}$	=	$q_s * K_z * C_{net,v} * K_{zt}$	= -97
		$P_{net,leeward}$	=	$q_s * K_z * C_{net,leeward} * K_{zt}$	= -83
		$P_{net,sidewall}$	=	$q_s * K_z * C_{net,sidewall} * K_{zt}$	= -97

Note: the force on the leeward and sidewall sides of unit will not be considered in the force analysis on the anchors. However, it will be considered when analyzing the forces on the individual panels. See pages 5-7.

Load Combinations

1605.3.1 $0.6 * D_L + 0.6 * W_L + H_L$ (Equation 16-15)

Dead Loads (lb)	D_L	=	Weight of unit
Lateral Earth Loads (lb)	H_L	=	0
Fluid Loads (lb)	F_L	=	0
Wind Loads (lb)	W_L	=	$F_w + F_L$



Calculate Centroid of unit (force from wind) (Figure 1)

$$Y = \frac{(H-1.00)(W) + ((H-1.00) / 2 + 1.00)(1.00)(W - 13.75)}{(H-1.00)(W) + (1.00)(W - 13.75)}$$

$$Y = \frac{(W*(H^2) / 2) - 6.875}{(W*H - 13.75)}$$

Case 1: Q5RF-060K

Case 2: P7RE-024K

where

W ₁ (in)	35
H ₁ (in)	38.2
L (in)	62

W ₂ (in)	35
H ₂ (in)	22.2
L (in)	49

Y ₁ (in)	19.29
---------------------	-------

Y ₂ (in)	11.29
---------------------	-------

CASE 1: Ground Mounted Units

Calculate Force from wind with velocity of 180 MPH (Figure 2)

$$F_w = P_{net} * A$$

HORIZONTAL FORCE

where

P _{net} (psf)	104.98
A ₁ (sqft)	16.45

where

P _{net} (psf)	104.98
A ₂ (sqft)	7.55

F _{w,1} (lbf)	1727
------------------------	------

F _{w,2} (lbf)	793
------------------------	-----

VERTICAL FORCE (LIFT)

where

P _{net,vert} (psf)	96.98
A _{1,H} (sqft)	15.07

where

P _{net,vert} (psf)	96.98
A _{2,H} (sqft)	11.91

F _{L,1} (lbf)	1461
------------------------	------

F _{L,2} (lbf)	1155
------------------------	------

Calculate Lifting Force on Side of Unit (Figure 3)

Unit consists of 2 Anchors per side

Load Combination

In the vertical direction, the load combination reduces to the weight of the unit and the lift force (Wt and F_L)

In the horizontal direction, the load combination reduces to just F_w.

$$M_o = (0.6*W_t + 0.6*F_L)*(D) + N*F_a*B - (0.6*F_w)*Y = 0$$

sum of moments = 0

$$F_a = \frac{(0.6*F_w*Y) - ((0.6*W_t + 0.6*F_L)*D)}{N*B}$$

where

W _{t1} (lb)	443
D ₁ (in)	17.5
B (in)	21.25
N	2

W _{t2} (lb)	230
D ₂ (in)	17.5
B (in)	21.25
N	2

F _{a1} (lbf)	722
Safety Factor	2.80

F _{a2} (lbf)	355
Safety Factor	5.69

Therefore, Two 1/4"x1 3/4" Tapcon screws per side are sufficient to secure a ground mounted package unit.



Figure 1: Calculate Centroid

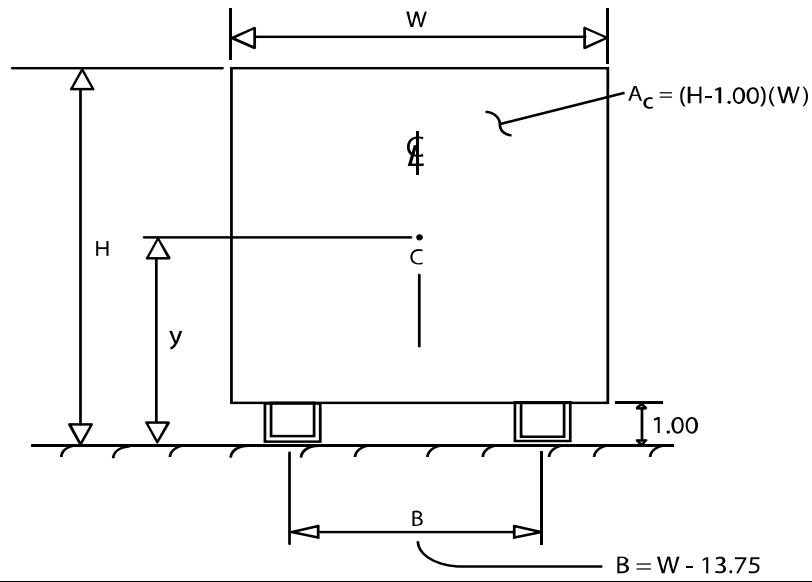

Figure 2: Calculate Wind Force

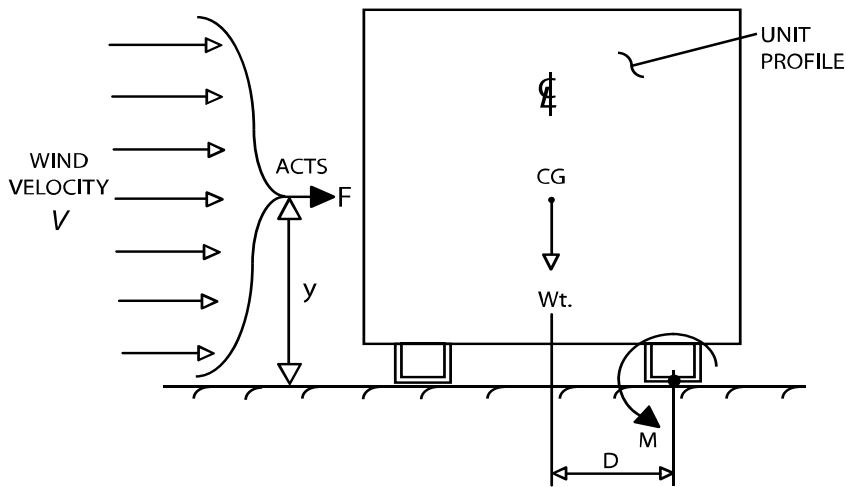
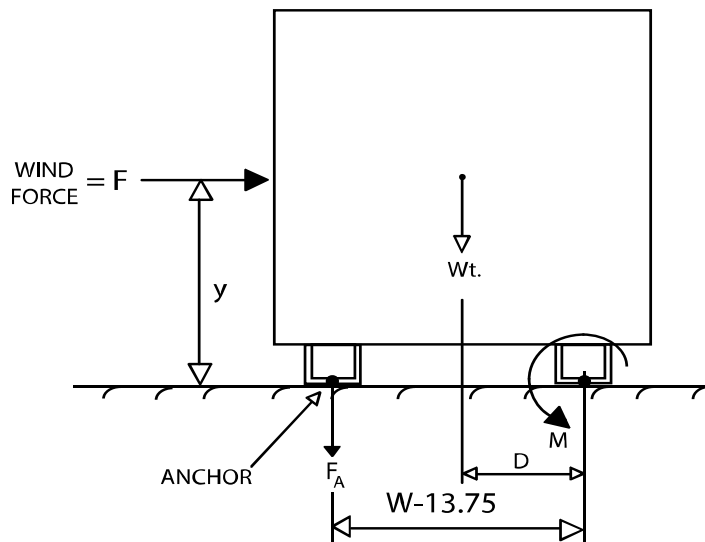

Figure 3: Calculate Lifting Force



Tapcon Concrete Anchors	
Dimensions	
Diameter (in)	0.25
Embedment Depth (in)	1.75

Mechanical Properties		
Tension Strength*		
Concrete Grade	Tension	Allowable Tension (lbs)
2000 psi	2020	505
4000 psi	2380	595
5000 psi	2770	692.5

Shear Strength*		
Concrete Grade	Shear	Allowable Shear
2000 psi	1670	418
4000 psi	1670	418
5000 psi	1670	418

<http://www.concretefasteners.com/anchors-fasteners/tapcon-screw/technical-specifications.aspx>

The "allowable" stress values listed above are assuming a safety factor of 4 per a recommendation from a website that said that generally it's good to use a safety factor of 4 for static loads.

Screw Material
C1022 Case Harden per SAE-J933

Screw Dimensions (Figure 4)	
Minor Diameter of Screw (in)	0.135
Shear Area of screw at Minor Diameter (sq.in)	0.0143

Screw Mechanical Properties	
Tensile Strength, Yield (psi)	52200
Shear Strength (psi)	31320

Force required to yield in tension, per screw (lbs)	747
Force required to yield in shear, per screw (lbs)	448

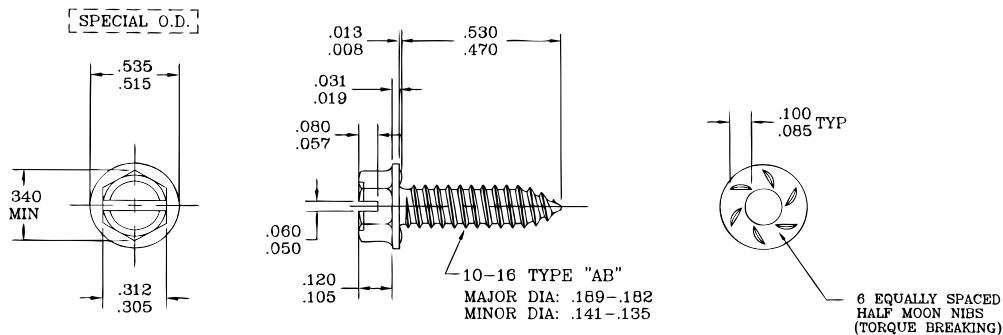

Figure 4: Panel Screw Dimensions



Panel Number	Description		
1	Top (1 of 2)		
	Number of screws in Tension	7	
	Tension Holding Force (lbs)		5230
	Number of screws in Shear	2	
	Area of panel (sf)	4.8	
	Wind pulling force (lbs)		-466
	Net Panel Holding Force (lbs)		4765

2	Top (2 of 2)		
	Number of screws in Tension	7	
	Tension Holding Force (lbs)		5230
	Number of screws in Shear	5	
	Area of panel (sf)	4.1	
	Wind pulling force (lbs)		-398
	Net Panel Holding Force (lbs)		4833

3	Duct Side		
	Number of screws in Tension	7	
	Tension Holding Force (lbs)		5230
	Number of screws in Shear	2	
	Area of panel (sf)	3.47	
	Wind pulling force (lbs)		-337
	Net Panel Holding Force (lbs)		4894

4	Back (1 of 3)		
	Number of screws in Tension	8	
	Tension Holding Force (lbs)		5977
	Number of screws in Shear	0	
	Area of panel (sf)	3.01	
	Wind pulling force (lbs)		-292
	Net Panel Holding Force (lbs)		5686

5	Back (2 of 3)		
	Number of screws in Tension	7	
	Tension Holding Force (lbs)		5230
	Number of screws in Shear	0	
	Area of panel (sf)	1.49	
	Wind pulling force (lbs)		-145
	Net Panel Holding Force (lbs)		5086

Panel Number	Description		
1	Top (1 of 2)		
	Number of screws in Tension	7	
	Tension Holding Force (lbs)		5230
	Number of screws in Shear	6	
	Area of panel (sf)	7.02	
	Wind pulling force (lbs)		-681
	Net Panel Holding Force (lbs)		4549

2	Top (2 of 2)		
	Number of screws in Tension	7	
	Tension Holding Force (lbs)		5230
	Number of screws in Shear	5	
	Area of panel (sf)	4.1	
	Wind pulling force (lbs)		-398
	Net Panel Holding Force (lbs)		4833

3	Duct Side		
	Number of screws in Tension	15	
	Tension Holding Force (lbs)		11208
	Number of screws in Shear	4	
	Area of panel (sf)	7.14	
	Wind pulling force (lbs)		-692
	Net Panel Holding Force (lbs)		10515

4	Back (1 of 3)		
	Number of screws in Tension	8	
	Tension Holding Force (lbs)		5977
	Number of screws in Shear	0	
	Area of panel (sf)	5.32	
	Wind pulling force (lbs)		-516
	Net Panel Holding Force (lbs)		5462

5	Back (2 of 3)		
	Number of screws in Tension	7	
	Tension Holding Force (lbs)		5230
	Number of screws in Shear	0	
	Area of panel (sf)	2.66	
	Wind pulling force (lbs)		-258
	Net Panel Holding Force (lbs)		4972



Panel Number	Description		
6	Back (3 of 3)		
	Number of screws in Tension	3	
	Tension Holding Force (lbs)		2242
	Number of screws in Shear	2	
	Area of panel (sf)	0.36	
	Wind Pulling Force (lbs)		-35
	Net Panel Holding Force (lbs)		2207

Panel Number	Description		
6	Back (3 of 3)		
	Number of screws in Tension	3	
	Tension Holding Force (lbs)		2242
	Number of screws in Shear	2	
	Area of panel (sf)	0.659	
	Wind Pulling Force (lbs)		-64
	Net Panel Holding Force (lbs)		2178

Panel Number	Description		
7	Side (1 of 2)		
	Number of screws in Tension	2	
	Tension Holding Force (lbs)		1494
	Number of screws in Shear	2	
	Area of panel (sf)	0.57	
	Wind Pulling Force (lbs)		-55
	Net Panel Holding Force (lbs)		1439

Panel Number	Description		
7	Side (1 of 2)		
	Number of screws in Tension	2	
	Tension Holding Force (lbs)		1494
	Number of screws in Shear	2	
	Area of panel (sf)	1.01	
	Wind Pulling Force (lbs)		-98
	Net Panel Holding Force (lbs)		1396

Panel Number	Description		
8	Side (2 of 2)		
	Number of screws in Tension	12	
	Tension Holding Force (lbs)		8966
	Number of screws in Shear	0	
	Area of panel (sf)	3.33	
	Wind Pulling Force (lbs)		-323
	Net Panel Holding Force (lbs)		8643

Panel Number	Description		
8	Side (2 of 2)		
	Number of screws in Tension	12	
	Tension Holding Force (lbs)		8966
	Number of screws in Shear	0	
	Area of panel (sf)	5.89	
	Wind Pulling Force (lbs)		-571
	Net Panel Holding Force (lbs)		8395

Therefore the unit can withstand the design forces without losing unit integrity.



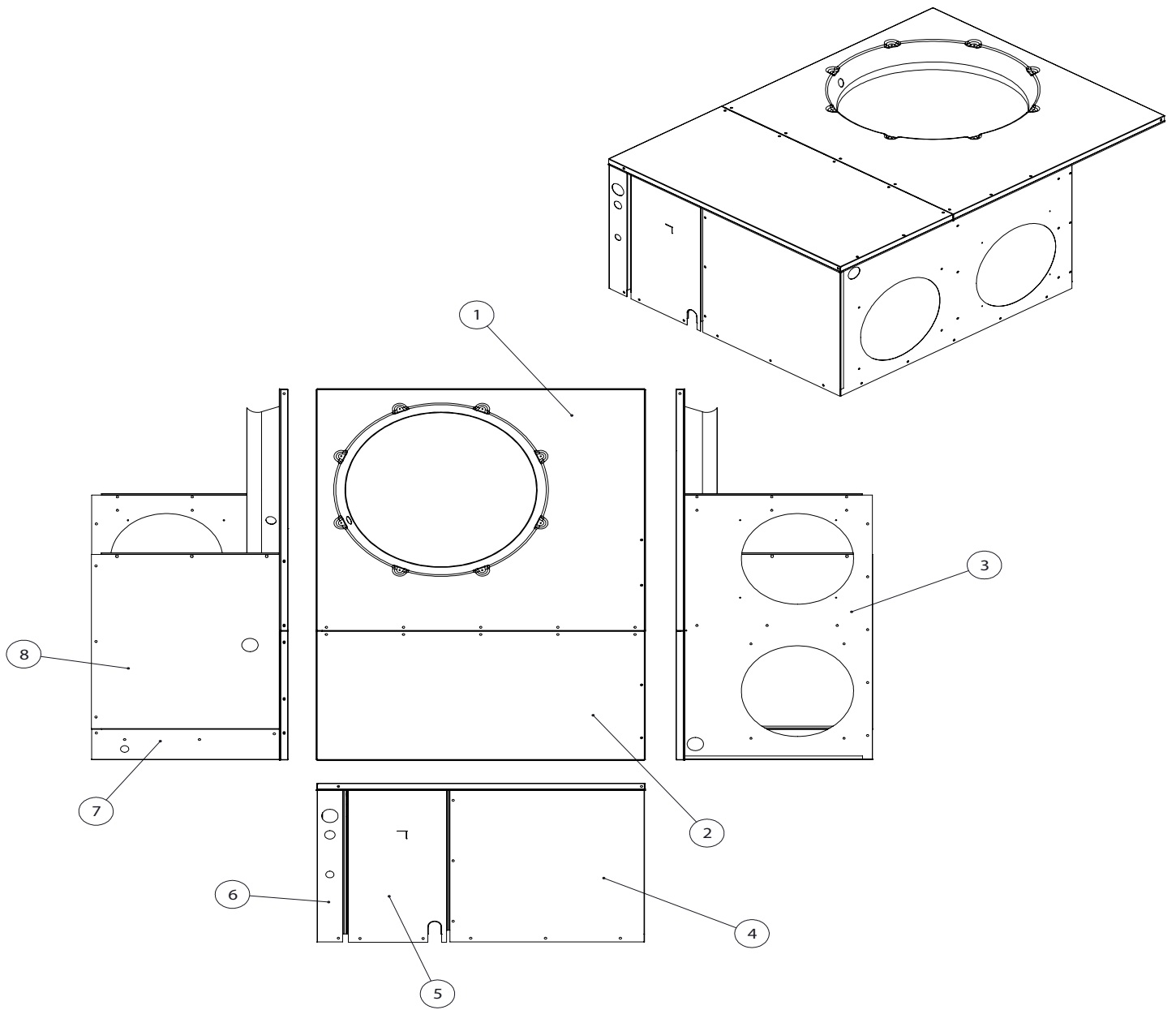

Figure 5. Panel Layout Single Package Unit



Screw Material	C1022 Case Harden per SAE-J933
Minor Diameter of Screw (in)	0.135
Area of screw at Minor Diameter (in ²)	0.0143
Tensile Strength, Yield (psi)	52200
Shear Strength (psi)	31320
Force required to yield in tension, per screw (lbs)	747
Force required to yield in shear, per screw (lbs)	448

Mechanical Properties		
Tension Strength*		
Concrete Grade	Tension (lbs)	Allowable Tension (lbs)
2000 psi	5396	1349
4000 psi	7852	1963

Shear Strength*		
Concrete Grade	Shear (lbs)	Allowable Shear (lbs)
2000 psi	3312	828
4000 psi	3428	857

* Source:

<http://www.concretefasteners.com/anchors-fasteners/tapcon-screw/technical-specifications.aspx>

Sheet metal Yield Strength (psi)	65000
Shear area of sheet metal hole (in ²)	0.002290221
	148.8643679
	0.182
	0.128
	0.091
	0.064



